

# De Faugères

## MANUEL D'ASSEMBLAGE ASSEMBLY INSTRUCTIONS

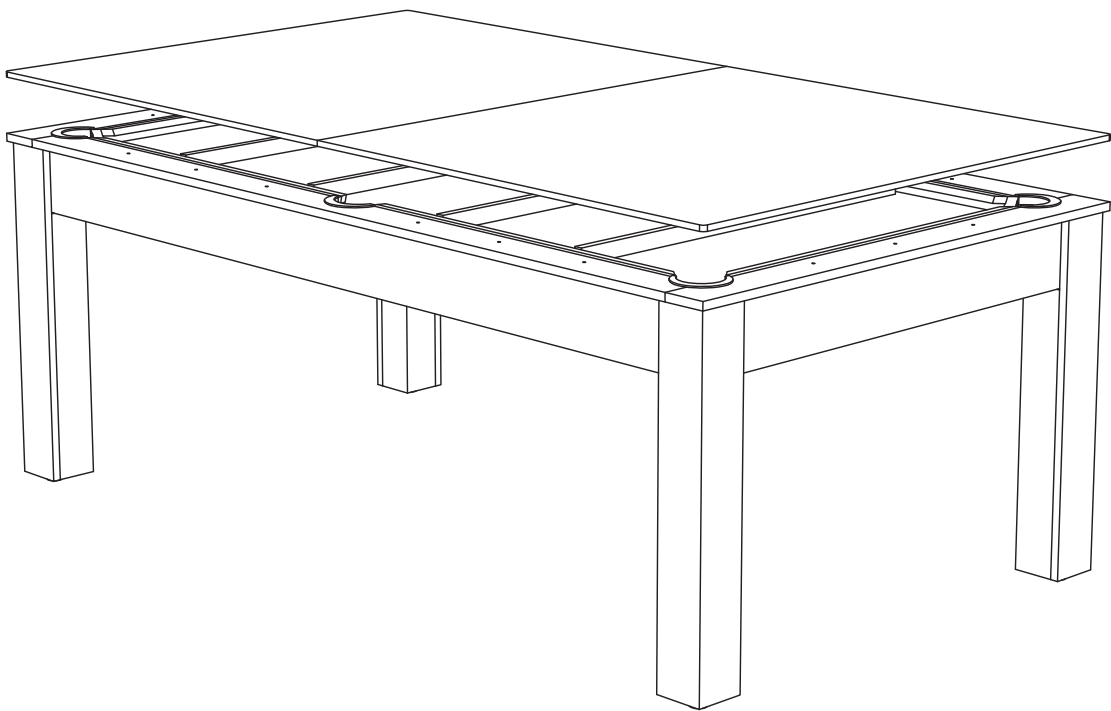

## BILLARD CONVERTIBLE 6 FEET - MODÈLE TEXAS 6 FEET DINING/POOL TABLE - TEXAS EDITION



*De Faugères*

Copyright De Faugères. All Rights Reserved.  
JG FASHION SARL | 450 ROUTE DE BORDENOUD | 38110 DOLOMIEU | FRANCE  
[www.defaugeres.eu](http://www.defaugeres.eu)

De Faugères est une marque enregistrée par JG Fashion SARL.  
Produits importés par JG Fashion SARL. Fabriqué en Chine.  
De Faugères is registered by JG Fashion SARL. Imported by JG Fashion SARL. Made in China.

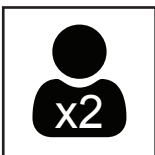

# TABLE DES MATIÈRES

## TABLE OF CONTENTS







- **PAGE 3-4**      ▪ **ASSEMBLAGE DU CADRE LATÉRAL**
  - *SIDE FRAME ASSEMBLY*
  
- **PAGE 5**      ▪ **ASSEMBLAGE DES PIEDS**
  - *LEGS ASSEMBLY*
  
- **PAGE 6-10**    ▪ **ASSEMBLAGE DU PLATEAU DE JEU**
  - *PLAYFIELD ASSEMBLY*
  
- **PAGE 11**      ▪ **ASSEMBLAGE DU CADRE SUPÉRIEUR**
  - *UPPER FRAME ASSEMBLY*
  
- **PAGE 12-13**    ▪ **ASSEMBLAGE DES BANDES**
  - *CUSHION RUBBER ASSEMBLY*
  
- **PAGE 14**      ▪ **ASSEMBLAGE DES POCHEs**
  - *POCKETS ASSEMBLY*
  
- **PAGE 15**      ▪ **VÉRIFICATION DE LA PLANÉITÉ**
  - *FLATNESS CHECK-UP*
  
- **PAGE 16**      ▪ **ASSEMBLAGE DES PLATEAUX DINATOIRES**
  - *DINING-TOP ASSEMBLY*

*Optionnel*
  
- **PAGE 17**      ▪ **ASSEMBLAGE DES PLATEAUX PING-PONG**
  - *PING PONG/DINING-TOP ASSEMBLY*

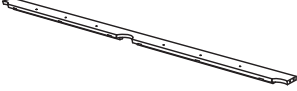
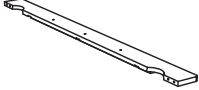
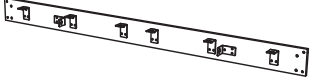
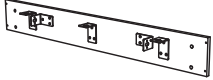
*Optionnel*

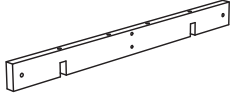
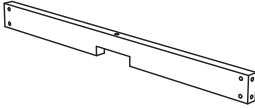

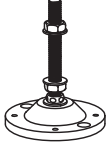
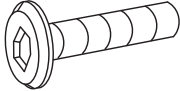
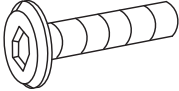
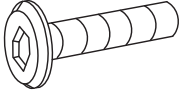
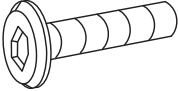
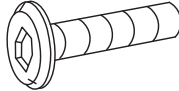
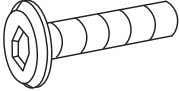
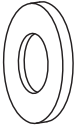
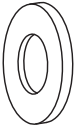
# ÉTAPE 1 : ASSEMBLAGE DU CADRE LATÉRAL

## STEP 1 : SIDE FRAME ASSEMBLY

<p><b>#1</b></p>  <p>Cadre supérieur long - 2pcs Long upper panel - 2pcs</p>	<p><b>#2</b></p>  <p>Cadre supérieur court - 2pcs Short upper panel - 2pcs</p>	<p><b>#3</b></p>  <p>Cadre latéral long - 2pcs Long side panel - 2pcs</p>	<p><b>#4</b></p>  <p>Cadre latéral court - 2pcs Short side panel - 2pcs</p>
<p><b>#5</b></p>  <p>Support métallique - 2pcs Iron playfield support - 2pcs</p>	<p><b>#6</b></p>  <p>Support bois - 2pcs Wooden playfield support - 2pcs</p>	<p><b>#7</b></p>  <p>Support bois - 1pc Wooden playfield support - 1pc</p>	<p><b>#8</b></p>  <p>Poche d'angle - 4pcs Corner pocket - 4pcs</p>
<p><b>#9</b></p>  <p>Poche latérale - 2pcs Side pocket - 2pcs</p>	<p><b>#10</b></p>  <p>Module de planéité - 1pc Flatness device - 1pc</p>	<p><b>#11</b></p>  <p>Vis 5/16"x55mm - 18pcs Bolt 5/16"x55mm - 18pcs</p>	<p><b>#13</b></p>  <p>Vis 1/4"x106mm - 8pcs Bolt 1/4"x106mm - 8pcs</p>
<p><b>#14</b></p>  <p>Vis 1/4"x70mm - 4pcs Bolt 1/4"x70mm - 4pcs</p>	<p><b>#15</b></p>  <p>Vis 1/4"x61mm - 6pcs Bolt 1/4"x61mm - 6pcs</p>	<p><b>#16</b></p>  <p>Vis 1/4"x41mm - 4pcs Bolt 1/4"x41mm - 4pcs</p>	<p><b>#17</b></p>  <p>Vis 1/4"x35mm - 4pcs Bolt 1/4"x35mm - 4pcs</p>
<p><b>#18A</b></p>  <p>Rondelle 5/16"x23mm - 18pcs Washer 5/16"x23mm - 18pcs</p>	<p><b>#19</b></p>  <p>Rondelle 1/4"x16mm - 30pcs Washer 1/4"x16mm - 30pcs</p>	<p><b>#20</b></p>  <p>Ecrou - 4pcs Nut - 4pcs</p>	<p><b>#21</b></p>  <p>Ecrou cylindrique - 4pcs Barrel nut - 4pcs</p>

# ÉTAPE 1 : ASSEMBLAGE DU CADRE LATÉRAL

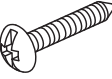
## STEP 1 : SIDE FRAME ASSEMBLY

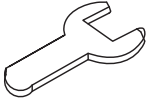
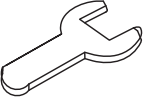
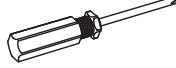

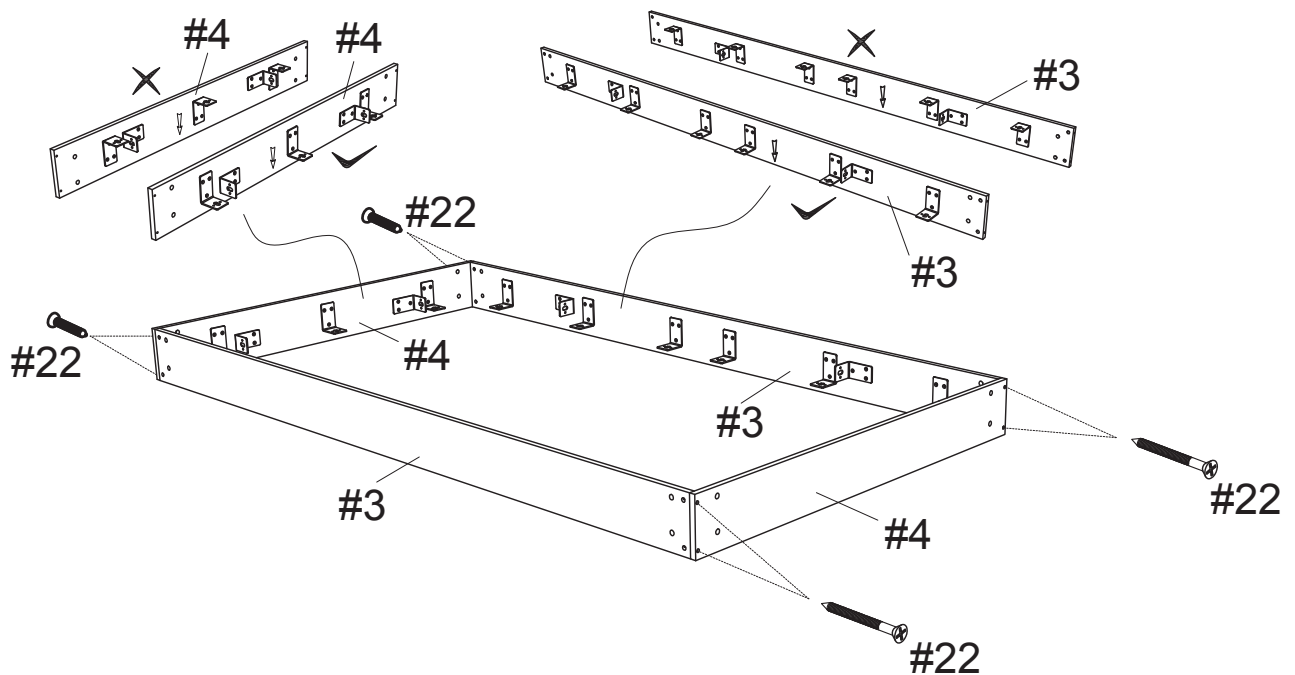

<p><b>#22</b></p>  <p>Vis F4x45mm - 8pcs Screw F4x45mm - 8pcs</p>	<p><b>#23</b></p>  <p>Vis T4x18mm - 4pcs Screw T4x18mm - 4pcs</p>	<p><b>#24</b></p>  <p>Vis T3x12mm - 12pcs Screw T3x12mm - 12pcs</p>	<p><b>#25</b></p>  <p>Clé à six pans - 1pc Hex key - 1pc</p>
<p><b>#26</b></p>  <p>Clé 19mm - 1pc Wrench 19mm - 1pc</p>	<p><b>#27</b></p>  <p>Clé 11mm - 1pc Wrench 11mm - 1pc</p>	<p><b>#28</b></p>  <p>Tournevis cruciforme - 1pc Phillips screwdriver - 1pc</p>	



L'ensemble des équerres doivent pointer vers le bas.  
*All square brackets should be pointing downwards.*

# ÉTAPE 2 : ASSEMBLAGE DES PIEDS

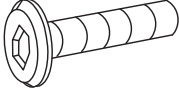
## STEP 2 : LEGS ASSEMBLY

<p>#29</p>  <p>Pied - 4pcs Leg - 4pcs</p>	<p>#30</p>  <p>Vérin réglable - 4pcs Leg leveler - 4pcs</p>	<p>#12</p>  <p>Vis 5/16"x28mm - 16pcs Bolt 5/16"x28mm - 16pcs</p>	<p>#18B</p>  <p>Rondelle 5/16"x23mm - 16pcs Washer 5/16"x23mm - 16pcs</p>
--	--	---	--

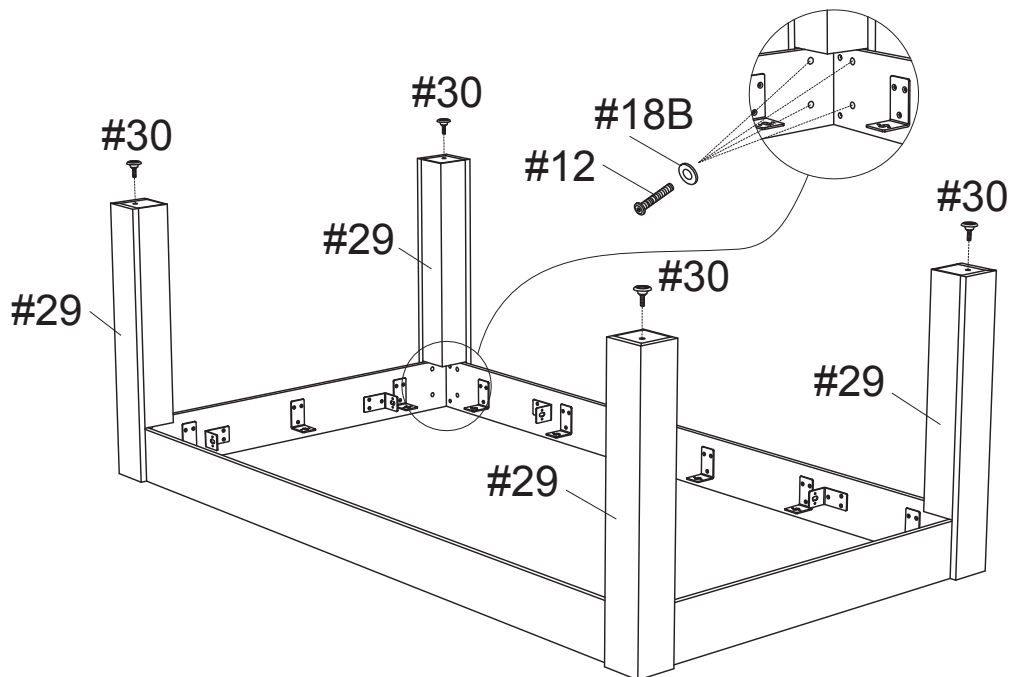

Ne pas visser les vérins au maximum, l'ajustement doit se faire une fois la table retournée.

Vérifier que les pieds sont bien positionnés en butée du cadre.

*Do not completely tighten the leg levelers to maximum as once the table is turned over, adjustments can then be made.*

*Ensure that the feet are correctly aligned with the frame.*

# ÉTAPE 3.1 : ASSEMBLAGE DU PLATEAU DE JEU

## STEP 3.1 : PLAYFIELD ASSEMBLY

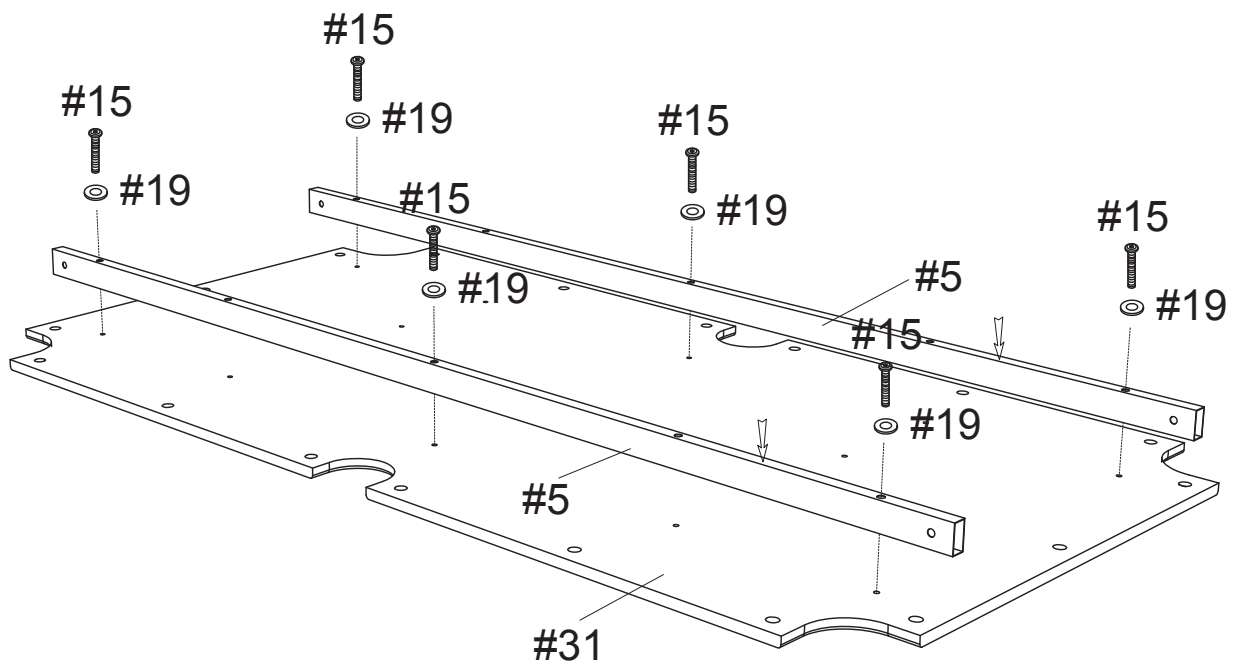
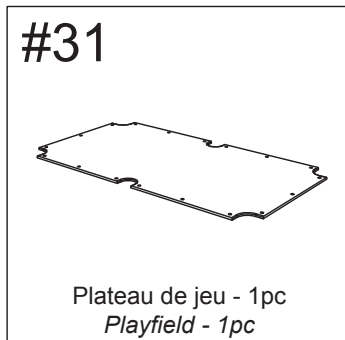

S'assurer que les supports métalliques soient symétriques et ne débordent pas du plateau de jeu.

En cas de remplacement du plateau, les pièces #15, #19 et #5 sont à récupérer sur votre billard actuel.

*Ensure that the metal supports are symmetrical and do not protrude from the game board.*

*In case of game board replacement, parts #15, #19 and #5 should be recovered from your current billiard table.*

# ÉTAPE 3.2 : ASSEMBLAGE DU PLATEAU DE JEU

## STEP 3.2 : PLAYFIELD ASSEMBLY

#31



Plateau de jeu - 1pc  
Playfield - 1pc

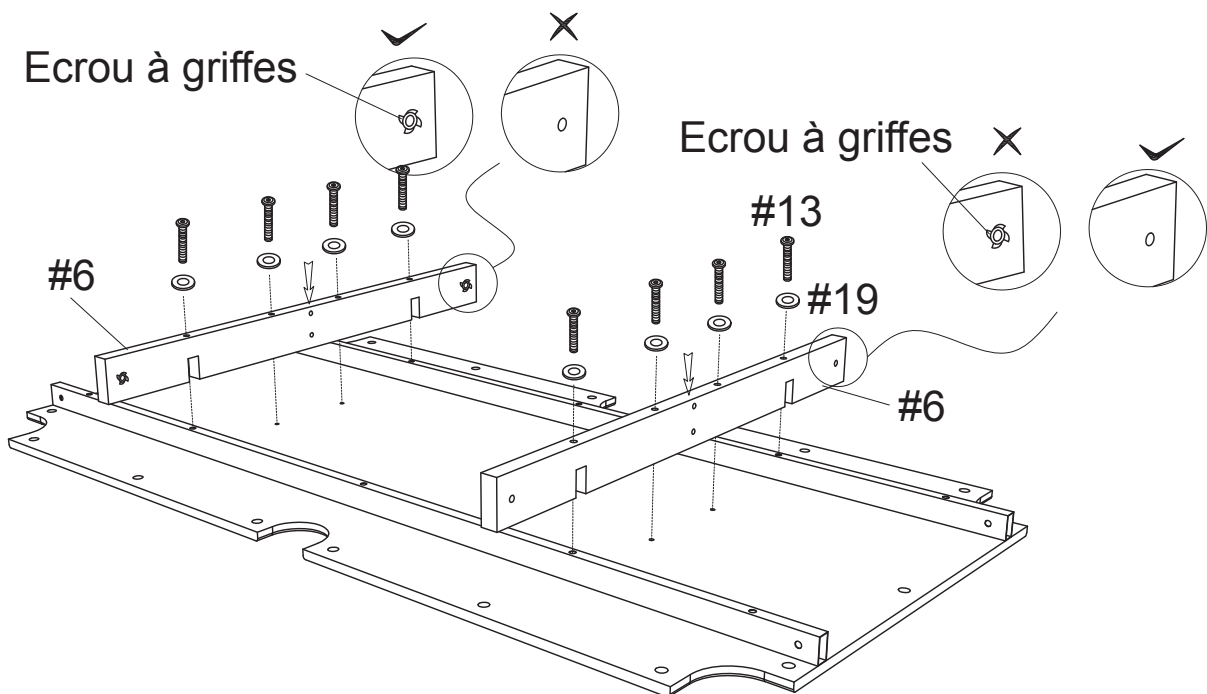

S'assurer que les écrous à griffes se font face.  
En cas de remplacement du plateau, les pièces #13, #19 et #6 sont à récupérer sur votre billard actuel.

*Ensure that the head of the bolts on the wooden supports face each other.*

*In case of game board replacement, parts #13, #19 and #6 should be recovered from your current billiard table.*

## ÉTAPE 3.3 : ASSEMBLAGE DU PLATEAU DE JEU STEP 3.3 : PLAYFIELD ASSEMBLY

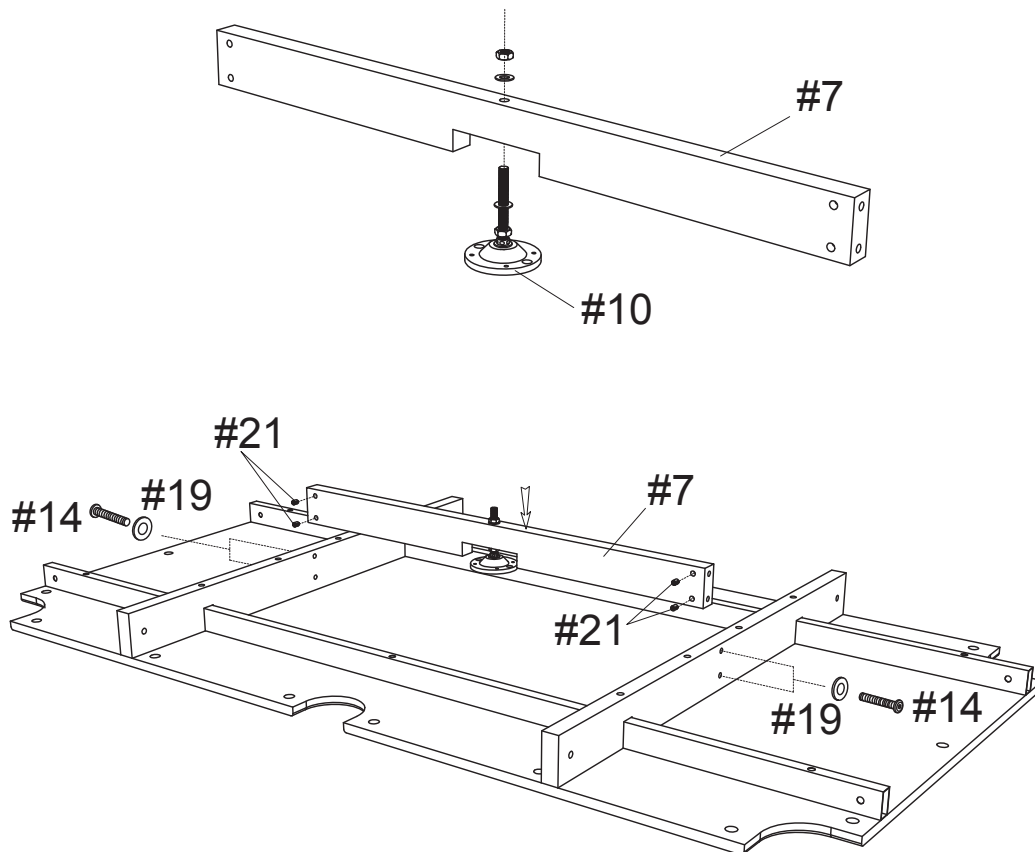
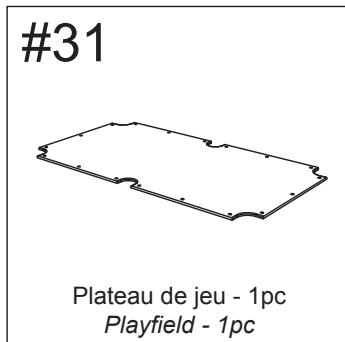

L'ajustement du module de planéité du plateau se fait une fois le billard assemblé et tout au long de son cycle de vie. En cas de remplacement du plateau, les pièces #7, #10, #14, #19 et #21 sont à récupérer sur votre billard actuel.

*Adjustment of the board flatness can be made once the billiard table is assembled and throughout it's shelf life. In case of game board replacement, parts #7, #10, #14, #19 and #21 should be recovered from your current billiard table.*



## ÉTAPE 3.4 : ASSEMBLAGE DU PLATEAU DE JEU STEP 3.4 : PLAYFIELD ASSEMBLY

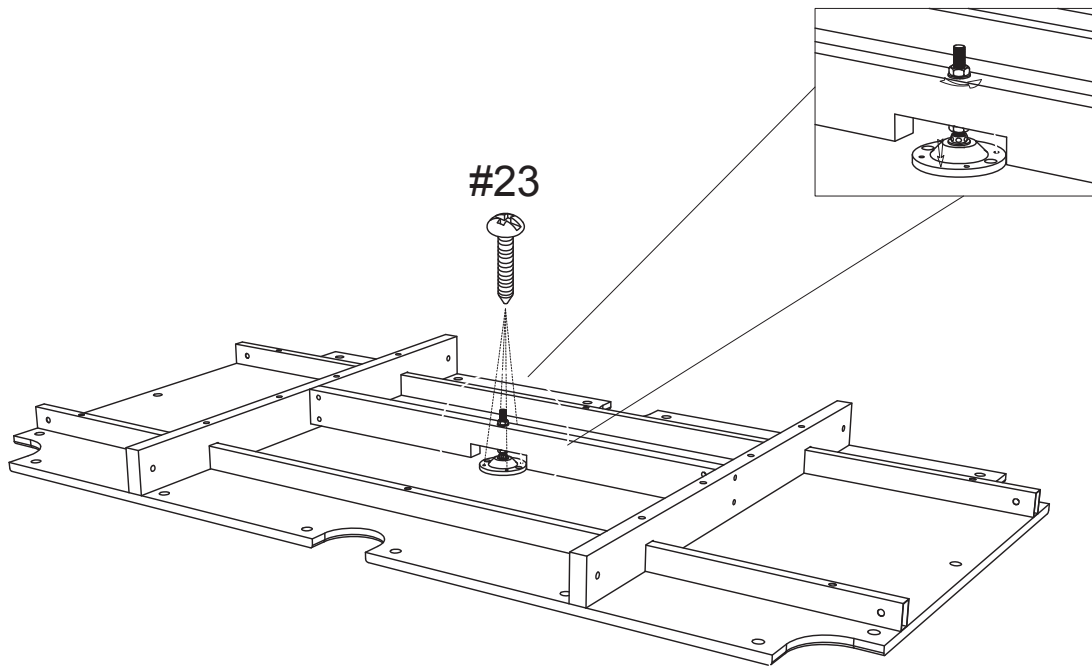
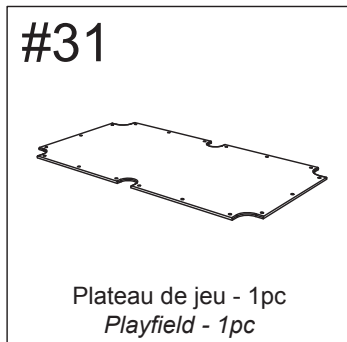

Desserrer le boulon du module de planéité (#10) avant de visser la pièce #23.

En cas de remplacement du plateau, la pièce #23 est à récupérer sur votre billard actuel.

*Loosen the flatness device piece before fixating piece 23 to maximum.*

*In case of game board replacement, part #23 should be recovered from your current billiard table.*

## ÉTAPE 3.5 : ASSEMBLAGE DU PLATEAU DE JEU STEP 3.5 : PLAYFIELD ASSEMBLY

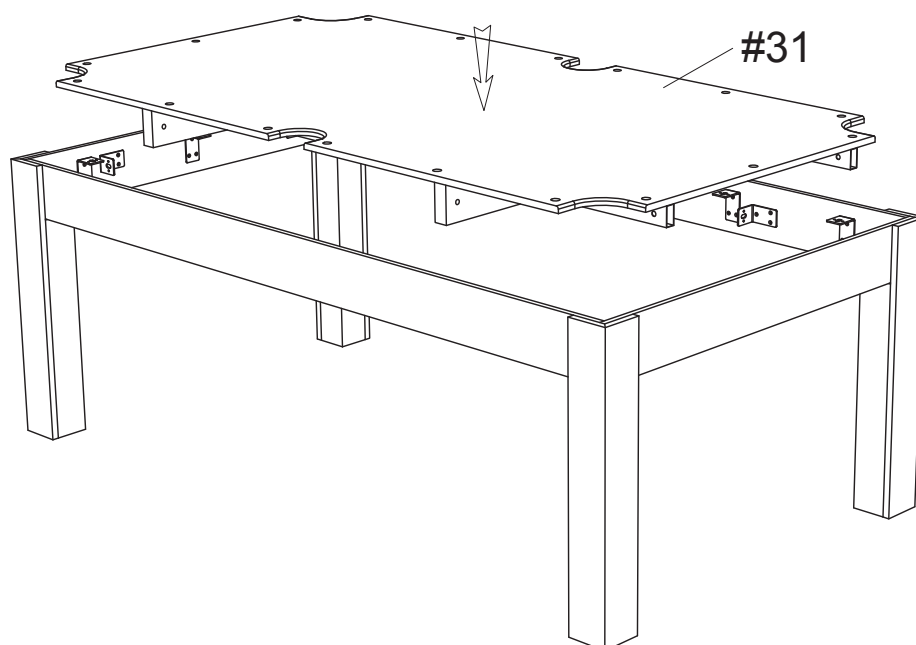
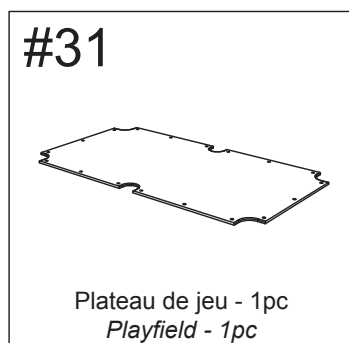

### **ATTENTION À VOS MAINS - RISQUE DE PINCEMENT**

Positionner les mains dans les encoches d'angle et descendre le plateau de manière totalement synchronisée.



### **WARNING- RISK OF HAND PINCHING**

*Place hands in the corner notches and slowly lower the platform in a synchronized manner.*

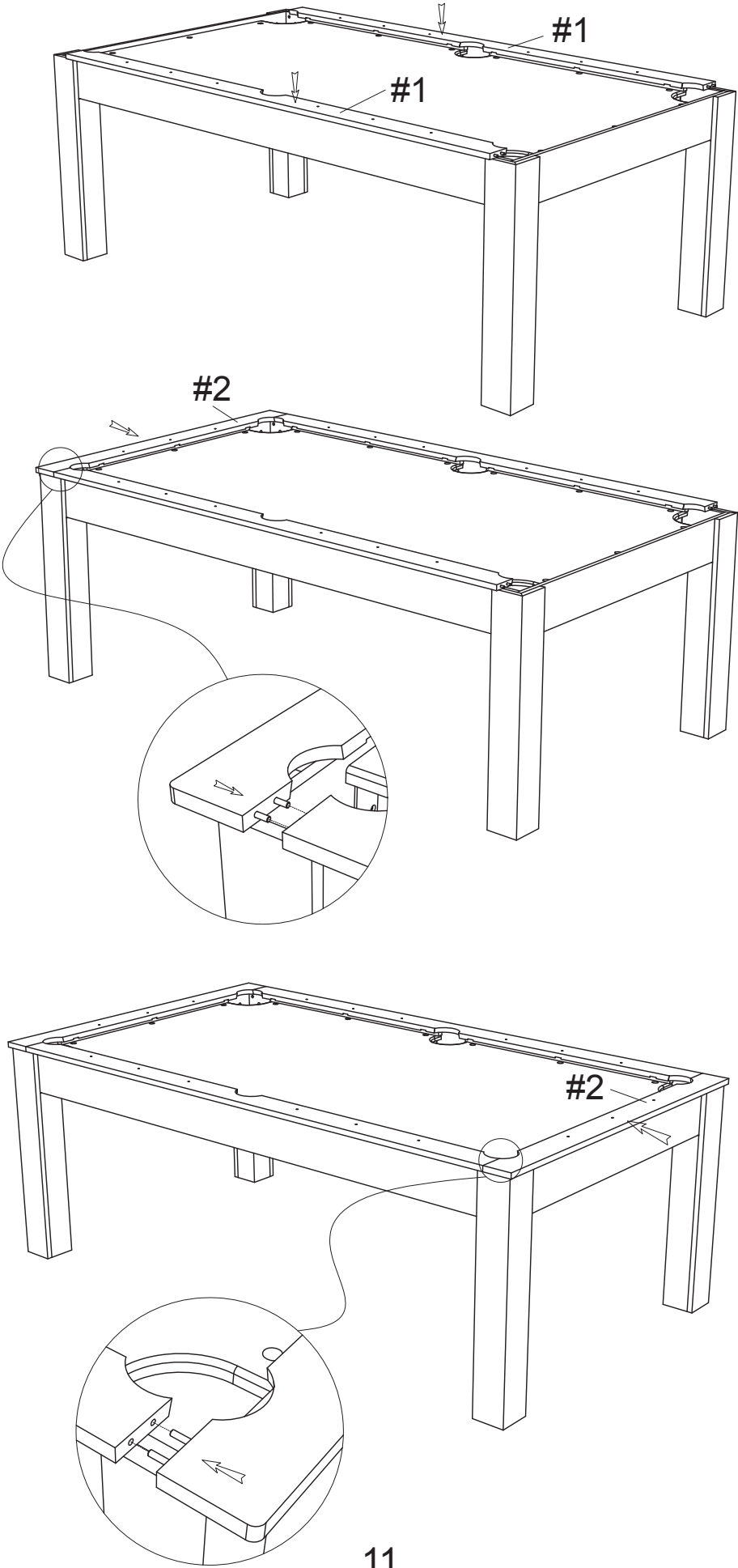
ÉTAPE 4 : ASSEMBLAGE DU CADRE SUPÉRIEUR  
STEP 4 : UPPER FRAME ASSEMBLY



# ÉTAPE 5.1 : ASSEMBLAGE DES BANDES STEP 5.1 : CUSHION RUBBER ASSEMBLY

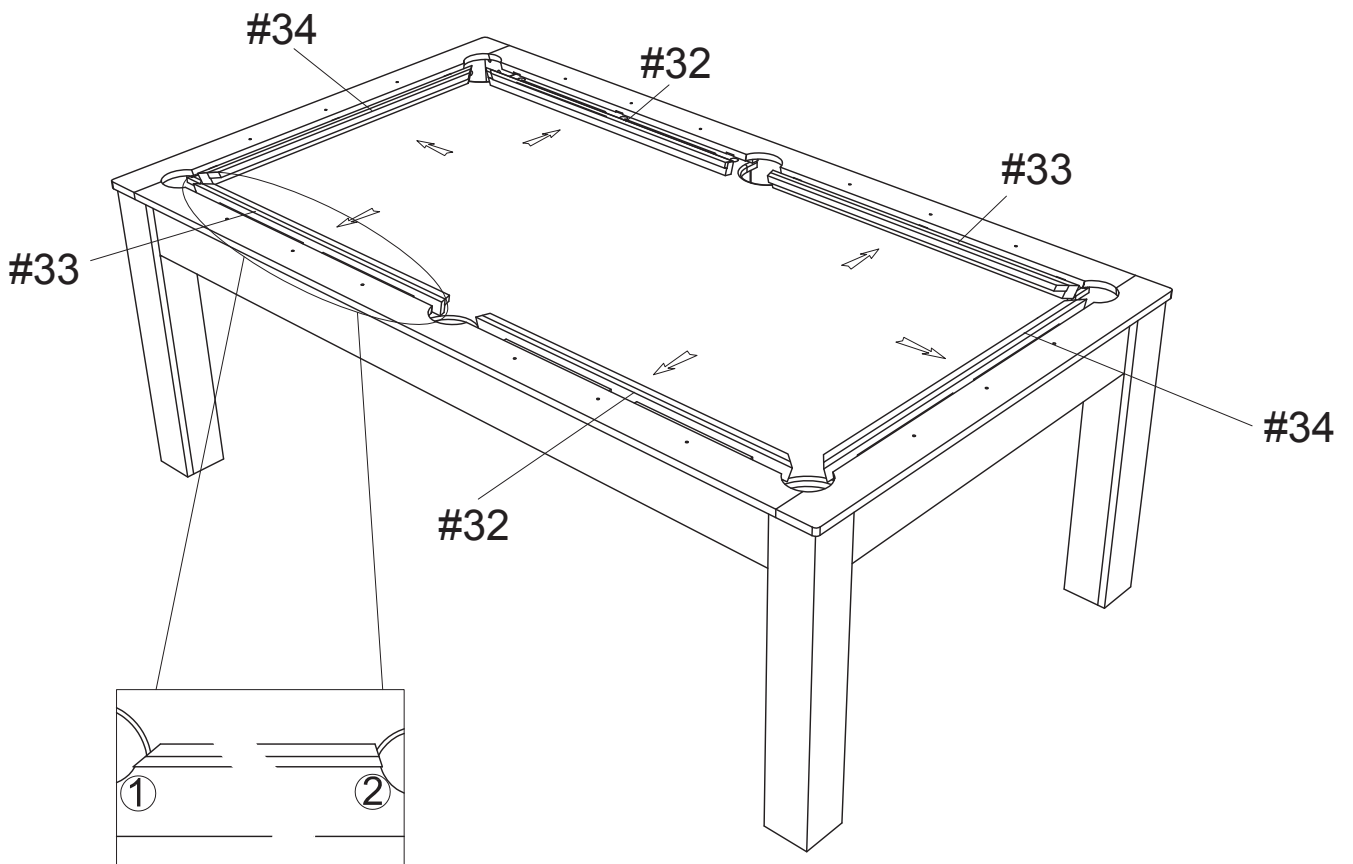

<p>#32</p>  <p>Bande de jeu - 2pcs Cushion rubber - 2pcs</p>	<p>#33</p>  <p>Bande de jeu - 2pcs Cushion rubber - 2pcs</p>	<p>#34</p>  <p>Bande de jeu - 2pcs Cushion rubber - 2pcs</p>
---	---	--



Veiller à bien centrer les bandes à leur emplacement respectif (cf. schéma ci-dessus) et à les laisser dépasser uniformément à chaque extrémité.

*Ensure as to centre the cushion rubbers in their respective locations (see diagram above), and allow them to evenly protrude at each end.*

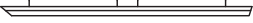
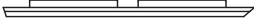
# ÉTAPE 5.2 : ASSEMBLAGE DES BANDES STEP 5.2 : CUSHION RUBBER ASSEMBLY

<p>#32</p>  <p>Bande de jeu - 2pcs Cushion rubber - 2pcs</p>	<p>#33</p>  <p>Bande de jeu - 2pcs Cushion rubber - 2pcs</p>	<p>#34</p>  <p>Bande de jeu - 2pcs Cushion rubber - 2pcs</p>
---	---	--

## VUE DU DESSOUS / VIEW FROM BELOW

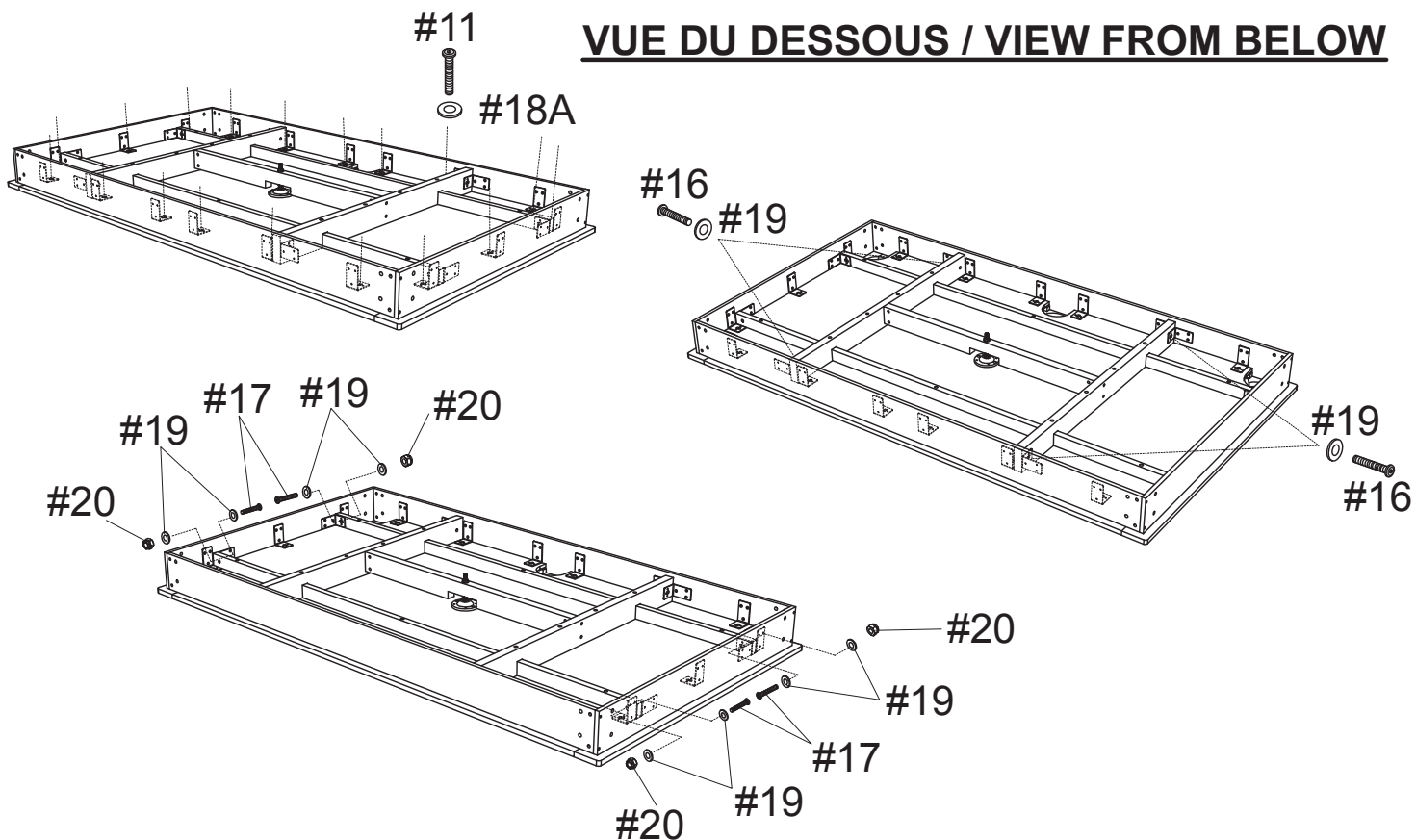

Serrer fortement afin de permettre aux bandes d'être solidement maintenues entre le plateau et le cadre.  
En cas de remplacement des bandes, l'ensemble de la visserie est à récupérer sur votre billard actuel.

*Tighten firmly to allow the cushion rubbers to be securely fastened between the flat board and the frame.*

*In case of replacement of the cushion rubbers, all screws and bolts should be recovered from your current billiard table.*

## ÉTAPE 6 : ASSEMBLAGE DES POCHES STEP 6 : POCKETS ASSEMBLY

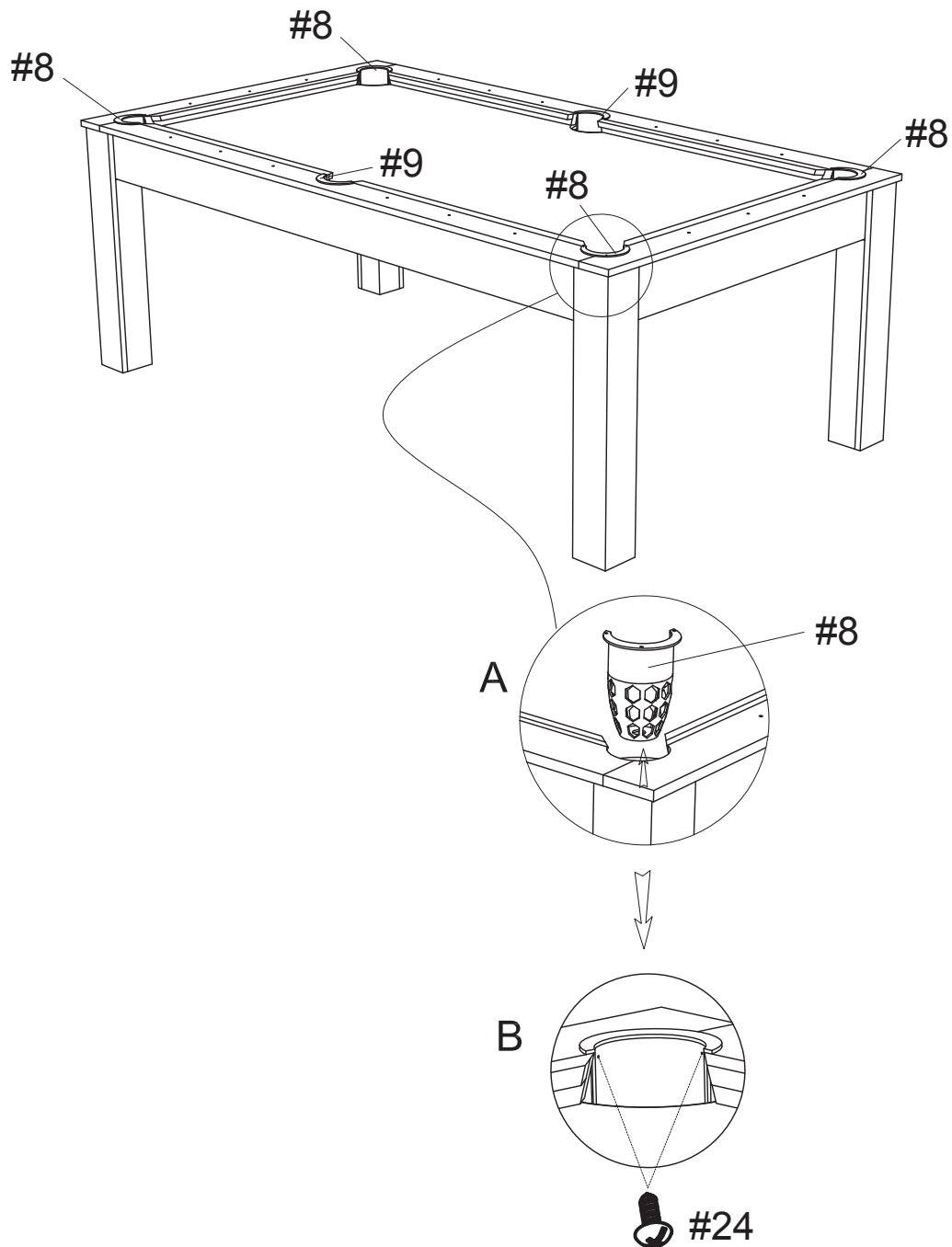

Pour plus de facilité, insérer les poches par le dessous. Veiller à bien les positionner avant de les visser horizontalement à l'aide du tournevis fourni.

*For ease, insert the pockets from below. Ensure as to position them well in place before fixing horizontally, using the screwdriver provided.*

## ÉTAPE 7 : VÉRIFICATION DE LA PLANÉITÉ STEP 7 : FLATNESS CHECK-UP

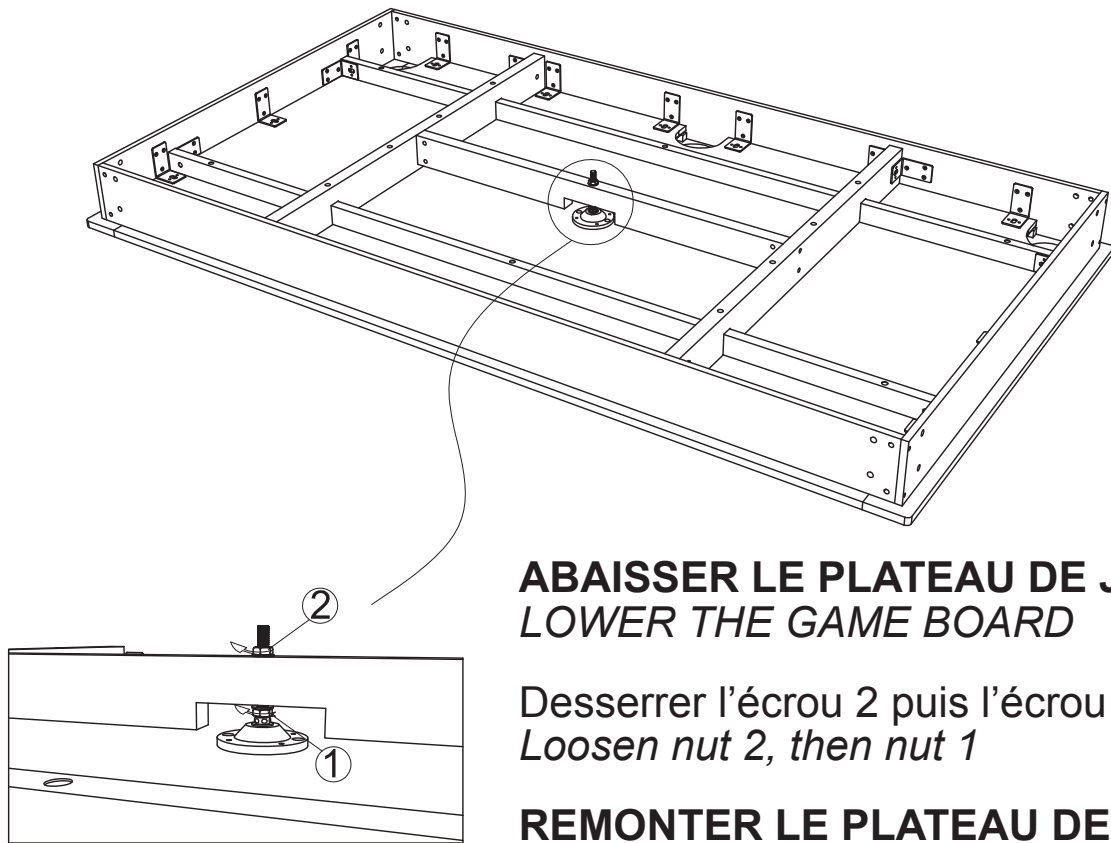

### **ABAISSER LE PLATEAU DE JEU LOWER THE GAME BOARD**

Desserrer l'écrou 2 puis l'écrou 1  
*Loosen nut 2, then nut 1*

### **REMONTER LE PLATEAU DE JEU UPPER THE GAME BOARD**

Serrer l'écrou 1 puis l'écrou 2  
*Tighten nut 1, then nut 2*

Utiliser un niveau à bulle pour vérifier la planéité de votre plateau et ajuster la hauteur des vérins pour une expérience de jeu optimale.

*Use a spirit level to check the flatness of your board and adjust the height of the jacks for optimum playing experience.*





Cette étape n'est nécessaire que si vous constatez un défaut de planéité pouvant être expliqué notamment par un prolongement d'utilisation dans un environnement humide (cave, sous-sol).

*This step is only necessary if you notice a flatness defect that can be explained, particularly by prolonged use in a humid environment (cellar, basement etc).*

# ÉTAPE 7 : ASSEMBLAGE DES PLATEAUX DINATOIRE

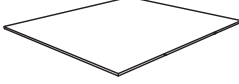
## STEP 7 : DINING-TOP ASSEMBLY

<p>#35</p>  <p>Plateau gauche - 1pc <i>Left-side table top - 1pc</i></p>	<p>#36</p>  <p>Plateau droit - 1pc <i>Right-side table top - 1pc</i></p>	<p>#37</p>  <p>Support plateau - 4pcs <i>Table-top support - 4pcs</i></p>
---	---	---

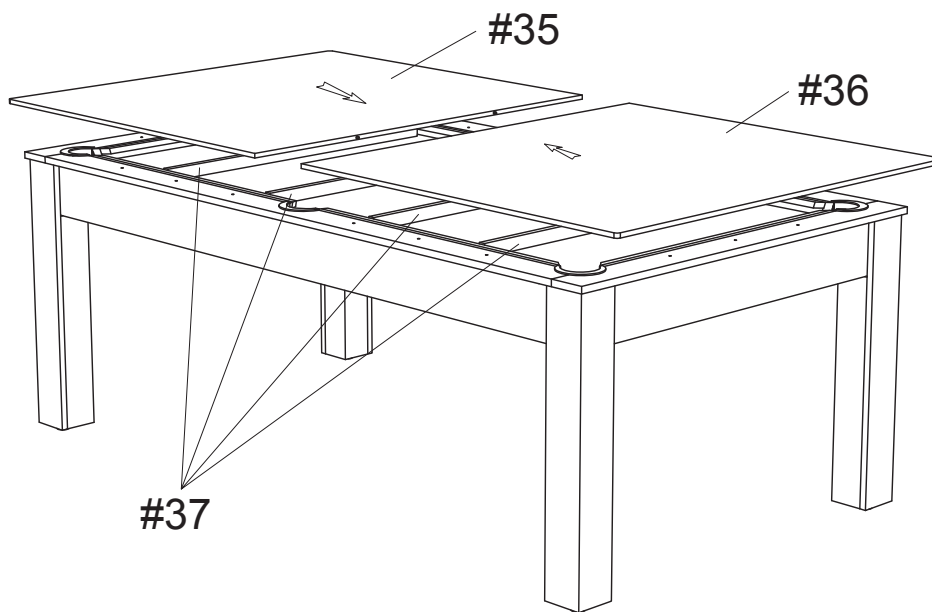





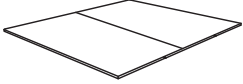
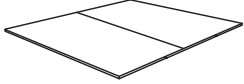

Positionner à intervalle régulier les supports afin d'homogénéiser la stabilité des plateaux.

*Position the table-top supports at regular intervals in order to standardize the stability of the table-tops.*

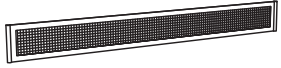

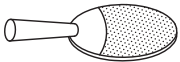
# ÉTAPE 7 : ASSEMBLAGE DES PLATEAUX PING-PONG STEP 7 : PING PONG/DINING-TOP ASSEMBLY

<p><b>#38</b></p>  <p>Plateau gauche - 1pc Left-side table top - 1pc</p>	<p><b>#39</b></p>  <p>Plateau droit - 1pc Right-side table top - 1pc</p>	<p><b>#40</b></p>  <p>Support plateau - 4pcs Table-top support - 4pcs</p>	<p><b>#41</b></p>  <p>Filet - 1pc Net - 1pc</p>
<p><b>#42</b></p>  <p>Support filet - 2pcs Net holder - 2pcs</p>	<p><b>#43</b></p>  <p>Raquette - 2pcs Racket - 2pcs</p>	<p><b>#44</b></p>  <p>Balle - 3pcs Ball - 3pcs</p>	

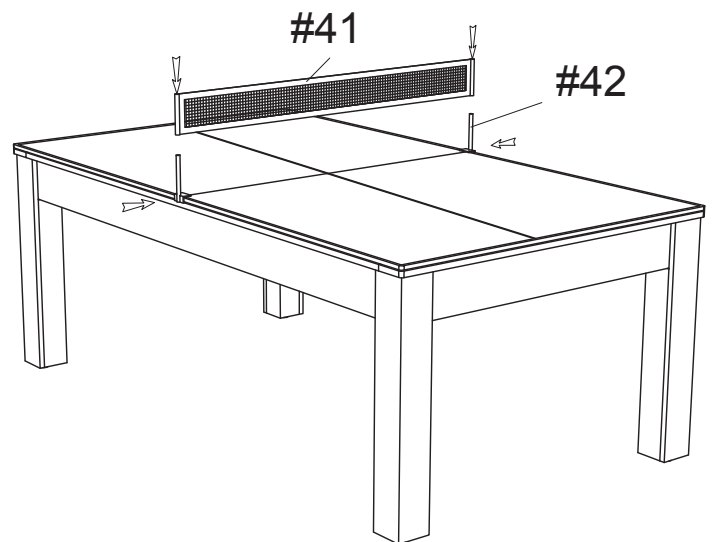
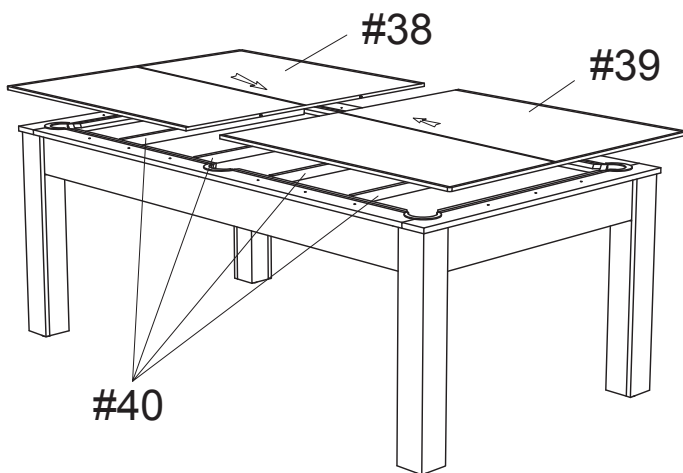

Positionner à intervalle régulier les supports afin d'homogénéiser la stabilité des plateaux.

*Position the supports at regular intervals in order to standardize the stability of the table-tops.*